

FILL-RITE®

H-SERIES FUEL TRANSFER PUMPS

FR1200, FR2400, FR4200, FR4400, FR600, SD1200, SD600
Installation and Operation Manual



MADE IN
USA 
WITH GLOBAL MATERIALS

GR
GORMAN-RUPP
COMPANY

Table of Contents

Limited Warranty Policy 2

About This Manual 2

Symbols and Definitions 3

Before You Begin 3

Safety Information 4

Installation 5

12V DC and 24V DC Wiring Instructions 7

115V AC Wiring Instructions 10

Operation Instructions 12

Security 12

Troubleshooting Guide 12

Specifications and Models 14

Performance Curves 17

Accessories 19

Pump Service Kits 21

Certifications 22

Motor Tag 22

Thank You!

Thank you for your loyalty to the Fill-Rite® brand of fuel transfer pumps. Your safety is important, so please read and thoroughly understand the procedures set forth in this manual. In addition, please save these instructions for future reference and record the model, serial number, and purchase date of your fuel transfer pump. Protect yourself as well as those around you by observing all safety instructions and adhering to all danger, warning, and caution symbols. Please register your Fill-Rite® product via info.fillrite.com/product_registration.

IMPORTANT RETURN POLICY

Please do not return this product to the store. For all warranty and product questions, please contact Fill-Rite Technical Support at 1 (800) 720-5192 or via email at FillRiteTech@fillrite.com (M-F, 8 AM – 5 PM ET).

MODEL#	
SERIAL#	
PURCHASE DATE:	

Limited Warranty Policy

Fill-Rite Company warrants the goods manufactured shall be free from defects of materials and workmanship. Specific warranty details for individual products can be found at fillrite.com.



H-Series Fuel Transfer Pumps Have the Following Features

- **Adjustable Electrical Junction Box**
Rotates 180 degrees to provide ease of electrical wiring installation in tight quarters no matter the inlet bung location
- **Reliable, Heavy-Duty Power Switch Lever**
Features a cast metal stop that withstands heavy use in the most rugged environments
- **Locking Bar Defense**
Elongated bar simplifies the pad locking process to prevent theft
- **Focused Component Weight Reduction**
Preserves expected heavy-duty performance while improving installation ease
- **Premium Paint Shield**
An exemplary corrosion resistant barrier for long field life
- **Thermally Protected Motor**
Prevents overheating to ensure maximum motor life
- **Telescoping Inlet Metal Suction Pipe***
Adjustable from 20 to 34 inches in length, allowing for universal installation on a multitude of tank sizes and shapes
*Not included with SD models
- **Intake Strainer Safeguard**
Protects the pump by blocking particles created by contamination
- **Certifications** – UL, cUL

About This Manual

From initial concept and design through final production, your Fill-Rite fuel transfer pump is built to provide years of trouble-free use. To ensure the safety of yourself and those around you, it is critical that this manual is read in its entirety prior to attempting to install or operate your new purchase. We strongly urge that any installer and operator become familiar with the terms, diagrams, and technical data in this manual and pay close attention to warning symbols and definitions. At Fill-Rite, your satisfaction with our products is paramount. If you have questions or need assistance with your product, please contact Fill-Rite Technical Support at 1 (800) 720-5192 (M-F, 8am-5pm ET).

Symbols and Definitions

 DANGER	Indicates a hazardous situation which, if not avoided, will result in death or serious injury.
 WARNING	Indicates a hazardous situation which, if not avoided, could result in death or serious injury.
 CAUTION	Indicates a hazardous situation which, if not avoided, could result in moderate or minor injury.
NOTICE	Indicates information considered important but not directly hazard related.

Before You Begin

Fueling Requirements

The Fill-Rite FR1200, FR2400, FR4200, FR4400, FR600 as well as SD1200 and SD600 models are designed and approved for use with the following flammable and combustible fluids: gasoline and gasoline blends up to 15% or E15, diesel, biodiesel blends up to 20% or B20, kerosene, and mineral spirits. Please take all necessary precautions when handling flammable liquids.

Power Source Requirements

Depending on the Fill-Rite model, supply line power will either be 12V DC, 24V DC, or 115V AC. The pump motor nameplate located next to the switch lever will provide detailed electrical information. Please refer to the appropriate electrical instructions found starting on **Page 7** (DC power) or **Page 10** (AC power).

Items that may be needed for installation:

Steel pipe wrench 14-24", open end wrench or socket (7/16", 11mm), T-25 Torx driver, utility knife, angle grinder or hacksaw (optional), wire cutters, wire stripper/crimper, and thread sealant (optional).

NOTE: Fill-Rite provides Teflon® tape for all models as listed on **Page 16**.

Safety Information

To ensure a safe installation and proper equipment operation, please read, understand, and adhere to all DANGER/WARNING/CAUTION and other NOTICES.

⚠ DANGER

Never smoke around or near a fuel tank or transfer pump. Open flames or a spark when pumping a flammable liquid will result in a fire. Improper electrical wiring or installation will result in serious injury or death.

⚠ WARNING

Electrical wiring should ONLY be performed by a licensed electrician in compliance with all local, state, and national electrical codes (NEC/ANSI/NFPA 30, NFPA 30A, and NFPA 70) as appropriate for the intended use of a Fill-Rite fuel transfer pump.

Threaded rigid conduit, sealed fittings, and conductor seal should be used where applicable and as defined by these codes.

This product must be properly bonded or grounded to avoid the build up of static electricity when handling flammable products. Static discharge may ignite vapors causing serious injury or death.

Fill-Rite pumps are not suited for use with water or fluids intended for human consumption. Do not use to fuel aircrafts.

To minimize static electricity build up, keep the nozzle in contact with the container being filled at all times during the filling process. Use only static wire conductive hose when pumping flammable liquid.

Improper mechanical installation or use can result in serious injury or death.

⚠ CAUTION

Threaded pipe joints and connections must be sealed with the appropriate sealant or sealant tape to prevent leaks.

All Fill-Rite pump models are equipped with thermal overload protection by which the motor will shut off to prevent heat damage. If motor is turned off by a thermal overload, turn the switch lever to the OFF position. Once the motor has cooled sufficiently, turn the switch lever to the ON position to resume fuel transfer.

Some Fill-Rite models will restart automatically if the switch lever is not in the OFF position once the thermal protector resets. As good practice, always place the switch lever in the OFF position when the motor overheats.

NOTICE

A filter should be used on the pump outlet to avoid contamination into the vehicle or equipment's fuel tank.

We recommend Fill-Rite filters for best results.

To prevent fuel storage tanks from shifting or tipping, refer to tank manufacturer's guidelines on proper anchoring.

Installation

Your Fill-Rite pump is designed to be mounted on a fuel tank via a threaded inlet flange supplied with the pump. Typical installations are shown in Diagram 1 and 2. Your pump features an integral bypass valve to recirculate the fluid when the pump is operating with the nozzle closed.

CAUTION

Do not use additional check valves or foot valves unless they have a proper pressure relief valve built into them. Please be aware that additional check valves will reduce flow rates.
 A pressure-retaining fill cap can be used to reduce fuel loss through evaporation.
 Threaded pipe joints and connections must be sealed with the appropriate sealant to prevent leaks.
 Use caution to prevent cross-threading during installation which can cause damage to either or both the inlet flange as well as storage tank bung.

NOTICE

In all tank applications, be sure the tank is properly secured per tank manufacturer's guidelines.

Stationary Tank

For stationary fuel tanks, the pump mounts to the tank bung by way of the pump inlet flange. Given the different sizes of stationary fuel tanks, a custom suction or inlet pipe may be necessary. We recommend 1" NPT black iron pipe that is extended to a length of at least 1-2" from the bottom of the tank, with the bottom of the pipe cut to an angle between 30-45 degrees for improved flow.

A stationary tank must be equipped with a vent cap. (Diagram 1)

Mobile Tank

For mobile fuel tanks, the pump mounts to the tank bung by way of the pump inlet flange.

For Telescoping Steel Suction Pipe

Allow telescoping tube to extend fully to the bottom of the tank.

For Custom or PVC Suction Pipe

To avoid penetrating the tank, we recommend leaving a minimum of 1-2" of the pipe off the bottom of tank. We further recommend cutting the suction pipe to a 30-45 degree angle for improved flow.

The mobile tank must be equipped with a vent cap. (Diagram 2)

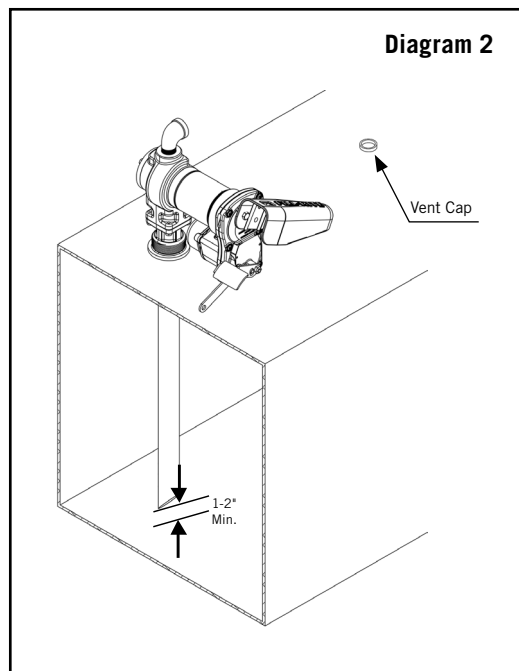
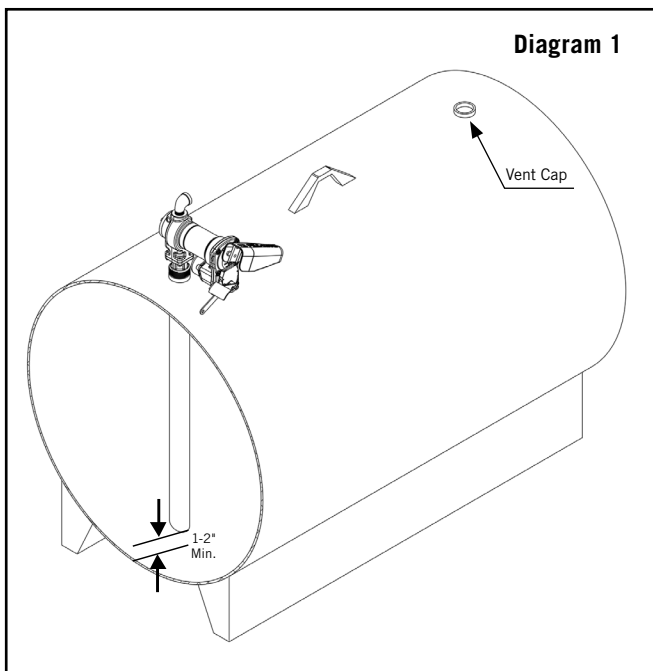

Installation Procedure

Step 1: (Optional) Inlet Flange Removal

Loosen (4) 1/4" bolts using 7/16" wrench or socket. Detach inlet bung from pump, retain bolts, screen, and gasket.

Step 2: Using either included suction pipe or custom pipe, thread pipe into inlet bung 1.5 to 2.5 turns past hand tight with pipe wrench. Use appropriate sealant for fuel transfer.

Step 3: Thread inlet bung with attached suction pipe onto tank 1.5 to 2.5 turns past hand tight. Use appropriate sealant for fuel transfer.

Step 4: (Only if Step 1 utilized) Place screen in screen pocket on the inlet bung, mount gasket, then place pump on tank bung. Align holes and insert (4) 1/4" bolts and tighten with 7/16" wrench to 40 in.-lbs. minimum.

Step 5: Remove junction box cover via (2) T-25 screws and locate wires. DC Voltage: 2 wires, Black and Red; AC Voltage: 3 wires, Black, White, and Green which is attached to internal ground screw. Ensure that gasket remains in place upon re-attachment of junction box.

Step 6: Feed wires from power source through NPT[†] opening into junction box. For DC models, use the black cable connector*. For AC models, attach conduit directly to NPT[†] opening.

Step 7: Nozzle boot is attached to switch plate via (1) 5/16" bolt torqued to 40 in.-lbs. The nozzle boot has two available position placements.

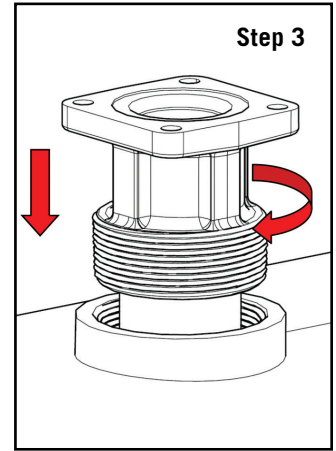
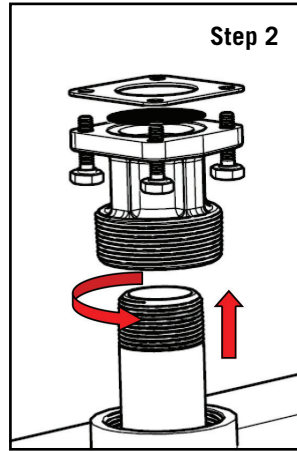

* Black cable gland only included with DC models

† 1/2" NPT to cable gland, bronze fitting per ATEX on HE Models

NOTICE

Maintain a minimum 1-2" separation from pipe end to bottom of tank.

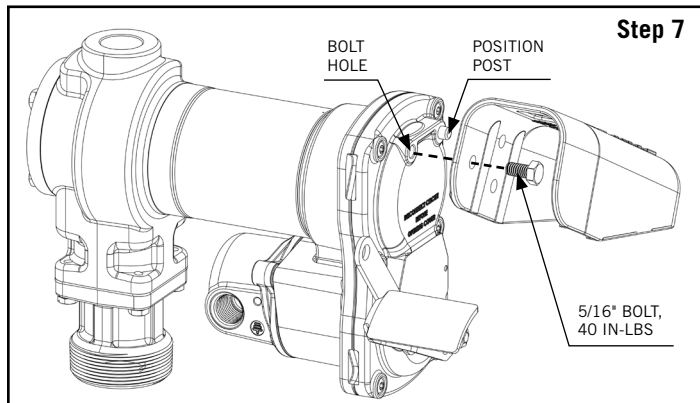
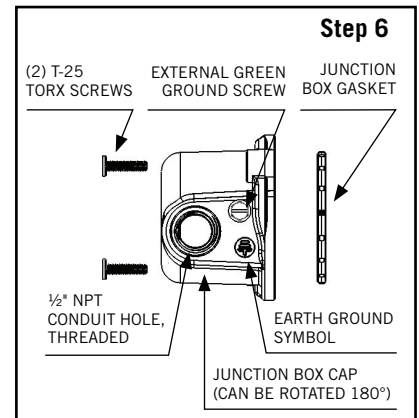
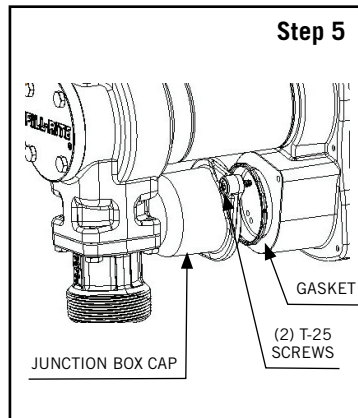
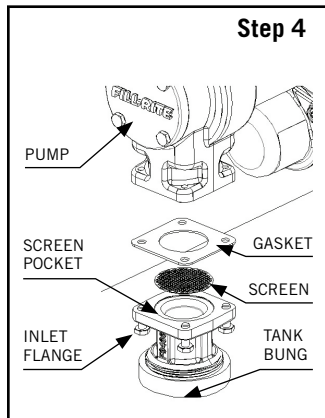

12V DC and 24V DC Wiring Instructions

FR1200 / FR2400 / FR4200 / FR4400 / SD1200 Series DC Transfer Pump

⚠ DANGER

Electrical wiring should be performed **ONLY** by a licensed electrician in compliance with local, state, and national electrical codes (NEC/ANSI/NFPA 30, NFPA 30A, and NFPA 70) as appropriate to the intended use of the pump. Threaded rigid conduit, sealed fittings, and conductor seal should be used where applicable. The pump must be properly grounded. Improper installation or use of this pump can result in serious personal injury or death.

Do not connect the positive or negative power to the green ground/earth screw or ground/earth wire as this could cause a fire.

Do not attempt to power the pump from vehicle wiring smaller than 12 AWG such as the cigarette lighter wire because these thin wires could overheat and cause a fire.

For wiring up to upfitter switches, please contact Fill-Rite Technical Support at 1 (800) 720-5192 (M-F, 8am-5pm ET).

⚠ CAUTION

Fill-Rite DC fuel pumps are designed to operate at the rated nameplate voltage. Series FR1200, FR4200, and SD1200 are rated for 12V DC while FR2400 and FR4400 are rated for 24V DC. Regardless of how supply line power is provided (i.e. via a battery or hard line), Fill-Rite requires the circuit contain a fuse to prevent against electrical shorts. For 12V DC, a 30 amp fuse is necessary while for the 24V DC circuit, a 20 amp fuse.

Voltage drop in wiring varies depending on the distance from the battery to the pump and the gauge of the wire used. If the distance is greater than the supplied 18' 12 AWG power cable*, refer to local, state, and national electrical codes to ensure the wire is of the correct size for this application.

The following chart is to be used as a reference and is not a substitute for electrical codes:

Maximum Linear Distance (FT) of Stranded Copper Wire Length by Gauge				
10	8	6	4	2
27'	44'	69'	110'	175'

**12 AWG power cable not supplied with pump only models*

NOTICE

Electrical bonding is the process of connecting metallic parts such as a fuel storage tank or transfer pump which may be exposed to electrical faults to a grounding conductor to ensure a low-resistance path to the ground. Bonding also provides a path for static electricity and induced voltages to drain out through the grounding path. The most common way to bond is with a copper wire.

If the intention is to operate either a 12V or 24V DC fuel transfer pump from a power supply other than a vehicle battery system, please contact Fill-Rite Technical Support at 1 (800) 720-5192 (M-F, 8am-5pm ET).

Instructions Before Proceeding with DC Wiring

The pump needs to be electrically bonded to a vehicle frame for mobile tanks or a ground rod for stationary tanks. To electrically bond pump for mobile application, remove the external factory installed green bonding screw located on the junction box cover (Diagram 3). Insert this screw through eyelet of furnished green bonding wire assembly and refasten it securely to the junction box. The other end of the wire is to be stripped of insulation and the bare wire securely bonded to the vehicle or on/off road trailer frame for mobile tanks (Diagram 4). For bonding with stationary tanks, attach a ground wire to a ground rod and the tank itself (Diagram 5). The distance may be greater than the supplied grounding wire.

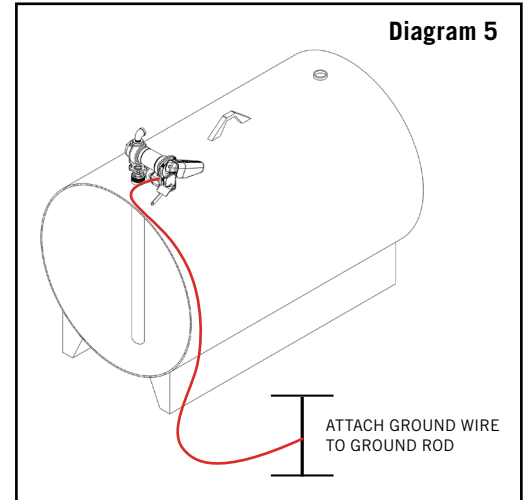
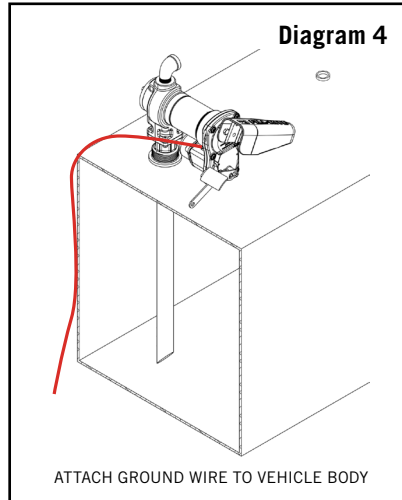
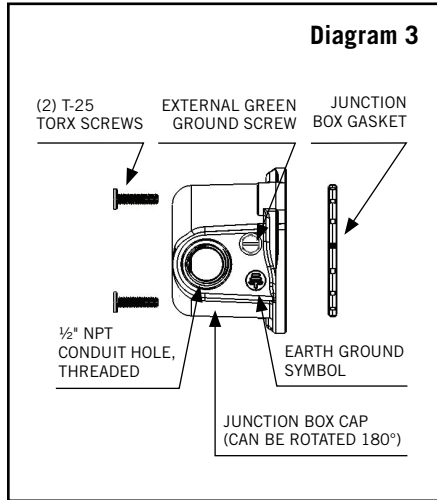

DC Wiring Instructions

1. Remove pump's electrical junction box cover and straighten the red and black wire.
2. Screw the furnished cable connector into 1/2" NPT conduit opening on the junction box.
3. Strip 3" of the outer covering from one end of the furnished electrical supply cable.* Be careful not to damage the black and red wire insulation.
4. Loosen cable connector nut and pass the stripped end of the furnished cable through the cable connector. Tighten the cable connector nut.
5. Strip 1/2" of the insulation from the ends of the red and black cable wires. Using the furnished wire nuts, connect the cable wires to the pump wires matching the colors.
IMPORTANT: Be sure no bare wire is exposed.
6. Fold wires into junction box and replace, making sure the cover gasket is in place. Make sure all screws are seated so there is no space between the frame and the junction box (see Step 6 diagram on **Page 6**).

*12 AWG cable not supplied with pump only models

Mobile Tank Wiring to a Vehicle Electrical System

1. Before electrical installation, place the switch lever into the OFF position to prevent accidental spillage once power is engaged to the motor.
2. Pass the electrical wires to the source of the vehicle power system, supporting as necessary and protecting them from sharp edges, heat, or anything that could cause damage.
3. To determine if the vehicle electrical system is negative (-) or positive (+) ground, check the battery marking of the terminal that is wired to the vehicle frame or motor block. The red wire from the pump will connect to positive battery post and the black wire from the pump will connect to negative battery post. These instructions focus on COMMON negative ground systems. UNCOMMON positive systems are a rare occurrence. Reference the drawing on **Page 9** for information on positive ground systems.
4. Fill-Rite requires installing a fuse holder and fuse (not provided) for protection of the purchased pump. Attach one end of the fuse holder to the end of the ungrounded wire, making a solid connection. The other end of the fuse holder is then attached to the ungrounded side of the battery, as close to the battery as possible. Make a solid electrical connection to the grounded side of the battery with the remaining wire. Utilizing a battery terminal connection (not provided by Fill-Rite) is required for completion of the electrical circuit.
5. Check all connections to make sure they are connected per instructions and all electrical codes. Install fuse (30 amp fuse for 12V DC; 20 amp fuse for 24V DC) into the fuse holder. Installation is now complete.

Mobile Tank Wiring to a Non-Vehicle System

While rare, there are instances where a 12V or 24V DC Fill-Rite fuel pump does not operate from a vehicle’s electrical system. In these cases, we recommend calling Fill-Rite Technical Support at 1 (800) 720-5192 (M-F, 8am-5pm ET) to discuss your specific situation. Most of these applications will require equipment not supplied by Fill-Rite. In addition, we want to ensure that the circuit will be able to handle the necessary power requirements of the pump.

Stationary Tank Wiring

1. Before electrical installation, place the switch lever into the OFF position to prevent accidental spillage once power is engaged to the motor.
2. Fill-Rite requires installing a fuse holder and fuse (not provided) for the protection of the purchased pump.
3. Attach one end of the fuse holder to the red pump wire, as close to the battery or power source as possible. Make a solid connection to the positive terminal of the power source with the other end of the fuse holder. Make a solid connection with the black pump wire to the negative terminal of the power source.
4. Check all connections to make sure they are connected per instructions and all electric codes.
5. Install fuse (30 amp fuse for 12V DC; 20 amp fuse for 24V DC) into the fuse holder.
6. The installation is now complete.

Negative Ground System (Common)

This electrical system is common within most vehicles utilizing a 12V DC power source. In this instance, the positive battery terminal supplies power to all devices such as the ignition system. The negative (-) terminal is connected to the vehicle’s frame.

Fuse to be located outside of hazardous area, as close to the power source as possible. If the wiring from the power source to the pump is greater than 18’, refer to the applicable Electrical Code (national, international, or local) to ensure the wire is of the correct size for the application.

Positive Ground System (Uncommon)

This electrical system is uncommon within most vehicles utilizing a 12V DC power source. The chassis of the vehicle is connected to the positive (+) terminal of the battery.

Fuse to be located outside of hazardous area, as close to the power source as possible. If the wiring from the power source to the pump is greater than 18’, refer to the applicable Electrical Code (national, international, or local) to ensure the wire is of the correct size for the application.

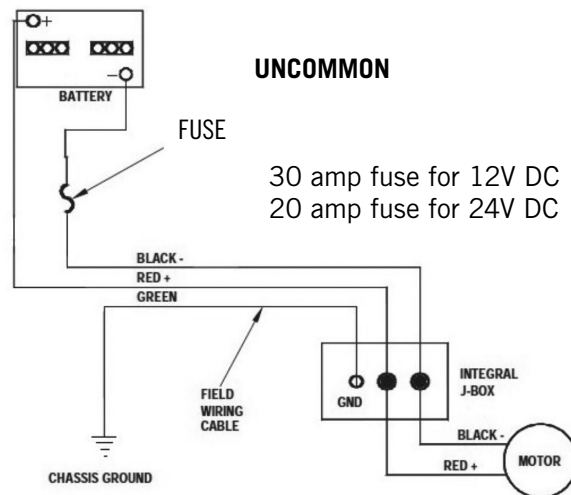
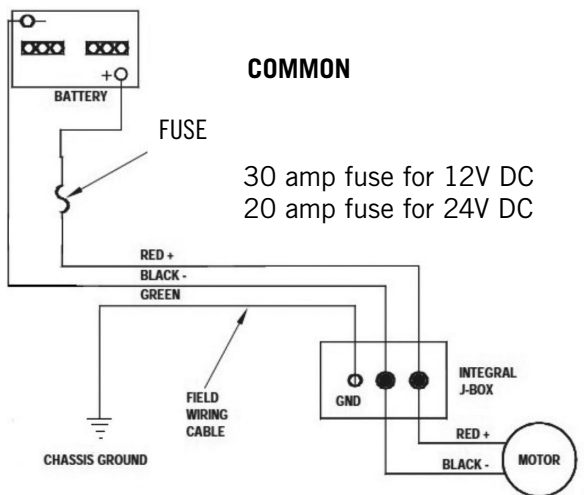

115V AC Wiring Instructions for FR600 / SD600 AC Fuel Transfer Pumps

⚠ DANGER

- All pumps will operate at the rated nameplate voltage.
- AC power should be supplied to the pump from a dedicated circuit with a 15 amp circuit protection. No other equipment should be powered by this circuit.
- Wiring must be of sufficient size to carry the correct current for the pump.
- Voltage drop will vary with distance to pump and size of wire; refer to the National Electrical Code (NEC) or local codes for voltage drop compensation to be sure you are using the correct size wire for your application. Undersized wires can overheat and cause a fire.
- Ensure proper grounding to avoid electrocution.
- Each Fill-Rite motor is labeled as explosion-proof for hazardous locations Class I / Division 1. It is highly recommended that any repairs be done by an authorized distributor to avoid voiding the warranty. It is very important to maintain the explosion-proof integrity of the motor and system components.
- Electrical wiring should be performed **ONLY** by a licensed electrician in compliance with local, state, and national electrical codes (NEC/ANSI/NFPA 70, NFPA30, and NFPA 30A) as appropriate to the intended use of the pump. The pump must be properly grounded. Improper installation or use of this pump can result in serious bodily injury or death.

⚠ WARNING

- Ground wire in supply wiring **MUST** be connected to the ground screw inside the junction box.

⚠ CAUTION

Voltage drop in wiring varies depending on the distance from the electrical source to the pump and the gauge of the wire used. Fill-Rite recommends referring to national, international, or local electrical codes to ensure the wire is of the correct size for your application. The following chart is to be used as a reference and is not a substitute to electrical codes.

Maximum Linear Distance (FT) of Solid and Stranded Copper Wire Length by Gauge								
	AWG	16	14	12	10	8	6	4
Wire	Solid	39	62	99	158	250		
	Stranded	38	61	96	154	245	389	620

115V AC Wiring Procedure

1. Remove the junction box cover and straighten the wires to make sure the stripped wire ends are accessible outside the junction box.
2. Install rigid conduit and appropriate wiring from power source to the junction box to maintain the explosion-proof integrity.
3. Connect the pump wires to the power supply lines according to the wiring diagram. Be certain to properly insulate the connections with the appropriate wire nuts or other connectors. **NOTE:** The ground wire **MUST** be connected. Ground wire connection is inside the junction box (Diagram 6b).
4. Fold the wires back into the junction box and replace the cover, making sure the cover gasket is in place.

115V AC Pump Junction Box (FR/SD600 Series AC Fuel Transfer Pumps)

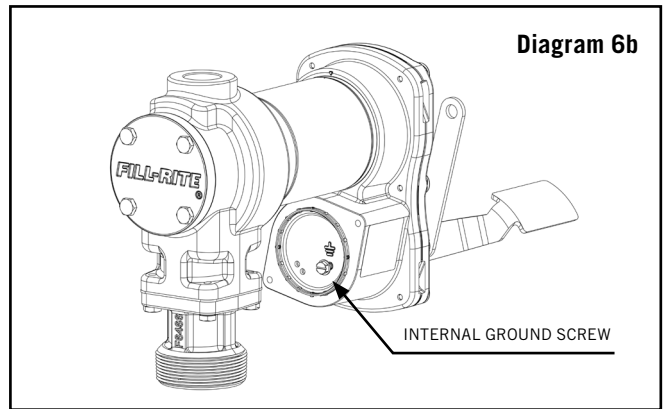
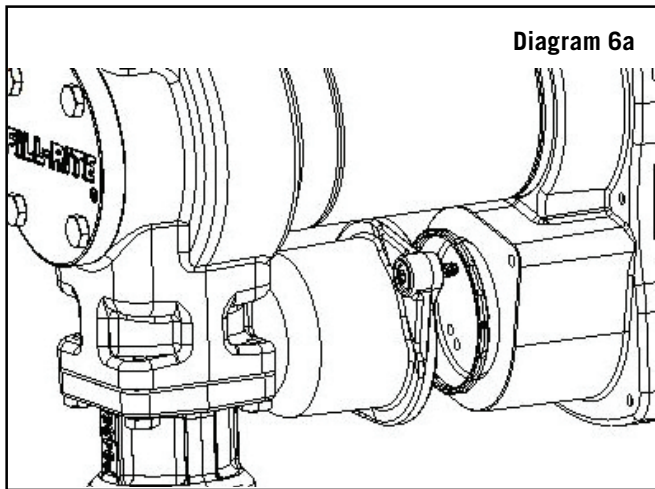

115V AC Wiring Diagram

115 VAC Wiring Diagram

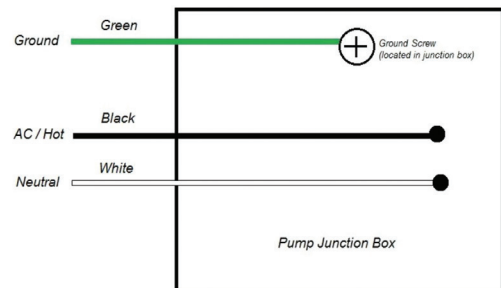

115V AC Wiring Diagram for FR/SD600 AC Fuel Transfer Pumps.

A ground wire must be included within the supply line power cable. This wire must be connected to the ground screw terminal on the inside of the junction box surface.

Switch Level Installation Instructions

Effective March 7, 2022, the fuel transfer pump on/off switch lever will need to be installed in the field. Please see Figure 1 for a visual guide on the proper installation of this lever.

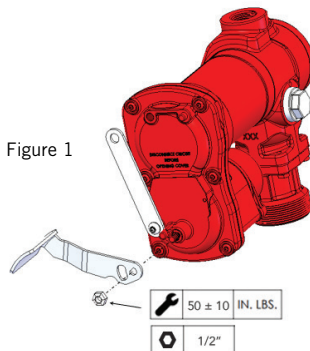

Operation Instructions

⚠ DANGER

Always keep the nozzle in contact with the container being filled during the filling process to minimize the possibility of static electricity build up. A spark around flammable vapors will cause an explosion resulting in death or serious injury.

1. If equipped, reset meter to “0” (do not reset while in use as this will cause damage to the meter).
2. Remove dispensing nozzle from nozzle boot.
3. Move the switch lever to the “ON” position to power the pump (Diagram 7).
4. Insert the dispensing nozzle into the container to be filled.
5. Operate the nozzle to dispense fluid; release nozzle when the desired amount of fluid has been dispensed.
6. Move switch lever to the “OFF” position (Diagram 8) to turn off the pump.
7. Remove the dispensing nozzle from the container being filled and store it in the nozzle boot.

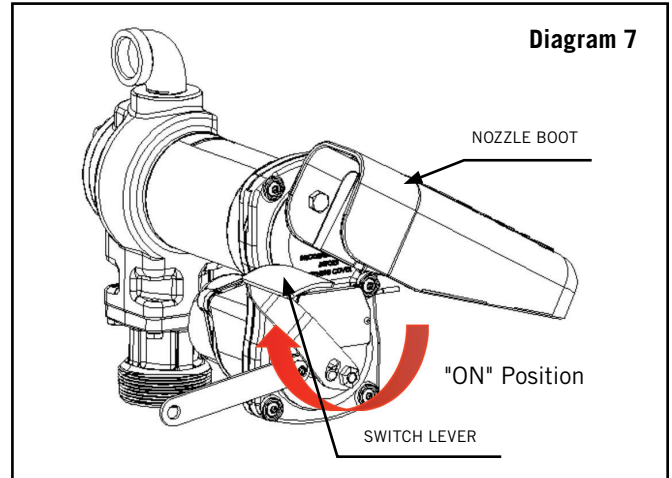

Security

Your Fill-Rite fuel transfer pump is equipped with a locking link located next to the switch lever for security. With the pump turned off and the nozzle in the stored position, a padlock can be inserted through the locking link and the nozzle handle.

Fill-Rite recommends a commercial grade laminated steel padlock with an adjustable shackle (Diagram 9).

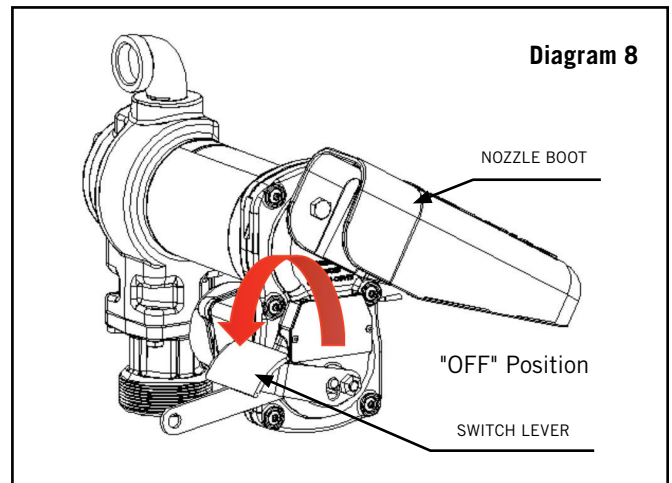
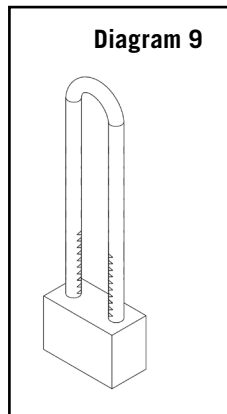

Troubleshooting

The following troubleshooting guide is provided to offer basic diagnostic assistance in the event you encounter abnormal service from your Fill-Rite fuel transfer pump. If you have questions, please feel free to contact Fill-Rite Technical Support at 1 (800) 720-5192 (M-F, 8am-5pm ET) or by email at FillRiteTech@fillrite.com.

⚠ DANGER

Please disconnect all power supply sources from either your AC or DC pump prior to performing any service or maintenance, as well as relieve any pressure within either the suction tube or discharge hose. Failure to do so can result in damage to the equipment and personal injury or death.

Troubleshooting (continued)

Symptom	Cause	Cure
Pump will not prime	Suction line problem	Check for leaks or restrictions in suction line
	Bypass valve open	Remove and inspect valve; must move freely and be free of debris
	Vanes sticking	Check vanes and rotor slots for nicks, burrs, and wear
	Excessive rotor or vane wear	Inspect rotor and vanes for excessive wear or damage; replace if necessary
	Automatic nozzle	Remove to prime pump
	System blockages	Check filter and bypass valve for debris; remove nozzle and test flow with pump ON
Low capacity	Excessive dirt in screen	Remove and clean screen
	Suction line problems	Check for leaks or restrictions in suction line
	Bypass valve sticking	Remove and inspect valve; must move freely and be free of debris
	Outlet blocked	Check pump outlet hose, nozzle, and filter for blockage
	Vanes sticking	Check vanes and rotor slots for wear; replace if necessary
	Excessive rotor or vane wear	Inspect rotor and vanes for excessive wear or damage; replace if necessary
	Hose or nozzle damage	Replace hose or nozzle (Fill-Rite recommends UL-rated hoses and nozzles)
	Plugged filter	Replace filter
Low fluid level	Fill tank	
Pump runs slowly	Incorrect voltage	Check incoming supply line voltage
	Vanes sticking	Inspect vanes and rotor slots for nicks, burrs, and wear
	Wiring problem	Check for loose connections
	Motor problem	Contact Fill-Rite Technical Support at 1 (800) 720-5192 (M-F, 8am-5pm ET)
Motor stalls, fuse blows, thermal protector trips repeatedly	Bypass valve sticking	Remove and inspect valve; must move freely and be free of debris
	Low voltage	Check incoming supply line voltage
	Excessive rotor or vane wear	Check rotor and vanes for excessive wear or damage
	Debris in pump cavity	Clean debris from pump cavity
Motor overheats	Transferring high viscosity fluids	These fluids can only be pumped for short periods of time (less than 30 minute duty cycle)
	Clogged screen	Remove inlet and clean screen
	Restricted suction pipe	Remove and clean pipe
	Motor failure	Contact Fill-Rite Technical Support at 1 (800) 720-5192 (M-F, 8am-5pm ET)
	Pump rotor lock-up	Clean and check pump rotor and vanes
Motor inoperable	No power	Check incoming supply line power
	Wiring issue	Use multimeter to isolate issue with supply line power
	Motor failure	Contact Fill-Rite Technical Support at 1 (800) 720-5192 (M-F, 8am-5pm ET)
	Locked rotor	Clean and check pump rotor; repair as needed with KIT120RG
	Incorrect/loose wiring	Verify correct wire size with local, state, and national electric codes
Fluid leakage	Bad O-ring gasket	Check and replace all O-ring gaskets (Rotor Cover / Inlet Flange / Bypass Cap)
	Dirty/bad shaft seal	Replace shaft seal with KIT120SL
	Incompatible fluid	Refer wetted parts list on Page 14 to the fluid manufacturer
	Loose fasteners	Tighten fasteners
Pump hums but will not operate	Motor failure	Contact Fill-Rite Technical Support at 1 (800) 720-5192 (M-F, 8am-5pm ET)
	Broken rotor key	Remove all debris and replace key

Specifications and Models

A series of fuel transfer pumps with UL/cUL, ATEX, IECEx, CE, EAC, and INMETRO certifications that are compatible with gasoline, diesel fuel, blended fuels such as biodiesel up to 20%, gasoline with up to 15% ethanol, mineral spirits, and kerosene.

Product Parts	Product Materials
Pump Housing	Cast Iron
Rotor	Powdered Iron
Vane	Sintered Bronze
Strainer Mesh	Stainless Steel
Wetted Components	Buna-N, Fluorocarbon, Ceramic, Cork, Thermoset, Steel, Stainless Steel

Description		FR1200	FR4200	SD1200	FR4400	FR2400	FR600	SD600	
Motor	Voltage, Supply (DC/AC)	12V DC			24V DC		115V AC / 60HZ		
	Power (HP)	1/4 TH						1/6 TH	
	Amps (Full Load)	26	28	26	18	15	2.5		
	Amps (Rated)	20	19	20	13	10	2.0		
	RPM	2600 RPM						2000 RPM	
	Power Cord*	Length	18'		15'	18'		Not Included	
		AWG	12						
	Duty Cycle	30 Minutes (on), then 30 Minutes (off)							
	Thermal Protection (motor)	Yes							
	Required Circuit Protection	30 AMP			20 AMP			15 AMP	

* Power cord not included in pump only models

Description		FR1200	FR4200	SD1200	FR4400	FR2400	FR600	SD600	
Pump	Maximum GPM	15	20	13	20	15	13		
	Bypass Pressure	16 PSI							
	Minimum Dry Vac	5 IN-HG							
	At Sea Level 70° F (21.1° C)	Suction Lift	8' Maximum						
		Outlet Head	37' Maximum						
	Inlet	1" NPT							
	Outlet	3/4" NPT*	1" NPT*	3/4" NPT*	1" NPT*	3/4" NPT*			
	Mount	H Models: 2" NPT Bung Adapter with 1" NPT Inlet HE Pump Only Models: 2" BSPT Bung Adapter with 1" BSPP Inlet							
	Warranty	Limited Lifetime Warranty [†]			1 Year	Limited Lifetime Warranty [†]			1 Year

[†] Warranty details can be found at fillrite.com

* HE pump only models have BSPP outlets

FR1200, FR2400, FR4400, FR600, SD1200, and SD600 (Dimensions displayed in inches)

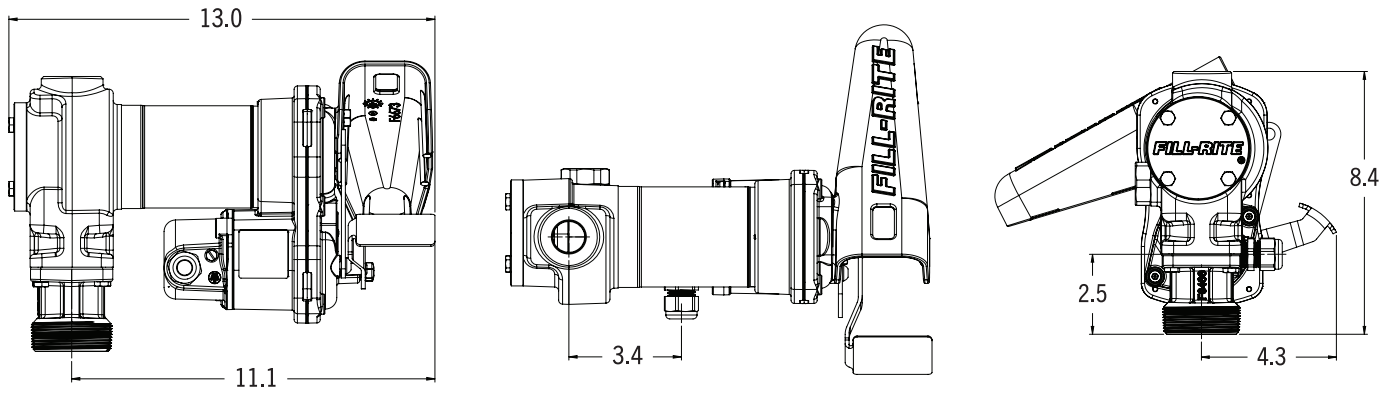

FR4200 (Dimensions displayed in inches)

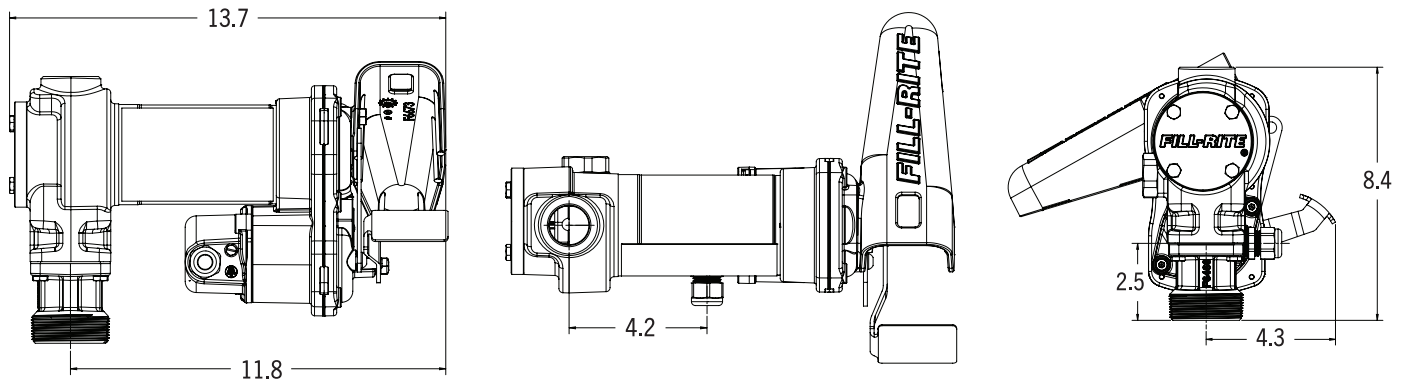

H-Series Model Information: FR1200, FR2400, FR4200, FR4400, FR600, SD1200, SD600

Model Number	Nozzle	Hose	Meter	Inlet Tube	Power Cord	Special	Voltage	Outlet		
FR1204H	Pump Only Model						12V DC	3/4"		
FR1210H	Manual	12'		Metal Telescoping 20" - 34 1/2"	12 AWG at 18'					
FR1210HA	Auto Gasoline	12'								
FR1210HA1	Auto Diesel	12'								
FR1210HARC	Auto Arctic	15'				Swivel				
FR1210HN										
FR1211H	Manual	12'	807C							
FR1211HL	Manual	12'	807CL							
FR1211HLN			807CL							
FR1211HN			807C							
FR1219H	Manual	12'	TT10AN							
FR1220HDSQ	Auto Diesel	18'				Swivel				
FR1220HDSFQ	Auto Diesel	18'				Swivel Filter				
FR2404H	Pump Only Model								24V DC	
FR2410H	Manual	12'				Metal Telescoping 20" - 34 1/2"	12 AWG at 18'			
FR2411H	Manual	12'	807C							
FR2411HL	Manual	12'	807CL							
FR4204H	Pump Only Model							12V DC	1"	
FR4210H	Manual	12'		Metal Telescoping 20" - 34 1/2"	12 AWG at 18'					
FR4210HARC	Auto Arctic	20'				Swivel				
FR4210HB	Ultra Hi-Flow	12'								
FR4210HD	Auto Diesel	12'								
FR4210HDS	Auto Diesel	12'				Swivel				
FR4210HBFQ	Ultra Hi-Flow	18'				10 AWG at 25' with clamps	Filter			
FR4210HN										
FR4211H	Manual	12'	901C			12 AWG at 18'				
FR4211HL	Manual	12'	901CL							
FR4211HLN			901CL							
FR4211HN			901C							
FR4219H	Manual	12'	TT10AN							
FR4220HDSQ	Auto Diesel	18'					Swivel			
FR4220HDSFQ	Auto Diesel	18'				Swivel Filter				

H-Series Model Information: FR1200, FR2400, FR4200, FR4400, FR600, SD1200, SD600 (continued)

Model Number	Nozzle	Hose	Meter	Inlet Tube	Power Cord	Special	Voltage	Outlet
FR4406H	Pump Only Model						24V DC	1"
FR4410H	Manual	12'		Metal Telescoping 20" - 34 1/2"	12 AWG at 18'			
FR604H	Pump Only Model						115V AC	3/4"
FR610H	Manual	12' UL		Metal Telescoping 20" - 34 1/2"				
FR610HA	Auto Gasoline	12' UL						
SD1202H	Manual	10'		PVC, 15 1/4" - 29 1/4"	12 AWG at 15'	12V DC		
SD1202HA	Auto Gasoline	10'			12 AWG at 15'			
SD602H	Manual	12' UL		PVC, 15 1/4" - 43 1/4"		115V AC		

HE-Series Model Information: FR1200E, FR2400E, FR4200E, FR4400E

Model Number	Nozzle	Hose	Meter	Inlet Tube	Power Cord	Voltage	Outlet	
FR1205HE	Pump Only Model						12V DC	3/4"
FR1210HE	Manual	12'		Metal Telescoping 20" - 34 1/2"	12 AWG at 18'			
FR1210HEA	Auto Gasoline	12'						
FR1211HEL	Manual	12'	807CL					
FR1211HELA	Auto Gasoline	12'	807CL					
FR2405HE	Pump Only Model						24V DC	3/4"
FR2410HE	Manual	12'		Metal Telescoping 20" - 34 1/2"	12 AWG at 18'			
FR2410HEA	Auto Gasoline	12'						
FR2411HEL	Manual	12'	807CL					
FR2411HELA	Auto Gasoline	12'	807CL					
FR4205HE	Pump Only Model						12V DC	1"
FR4210HE	Manual	12'		Metal Telescoping 20" - 34 1/2"	12 AWG at 18'			
FR4210HEB	Ultra Hi-Flow	12'						
FR4210HEBL	Ultra Hi-Flow	12'	901CL					
FR4211HEL	Manual	12'	901CL					
FR4405HE	Pump Only Model						24V AC	

1200 Series Performance Curve

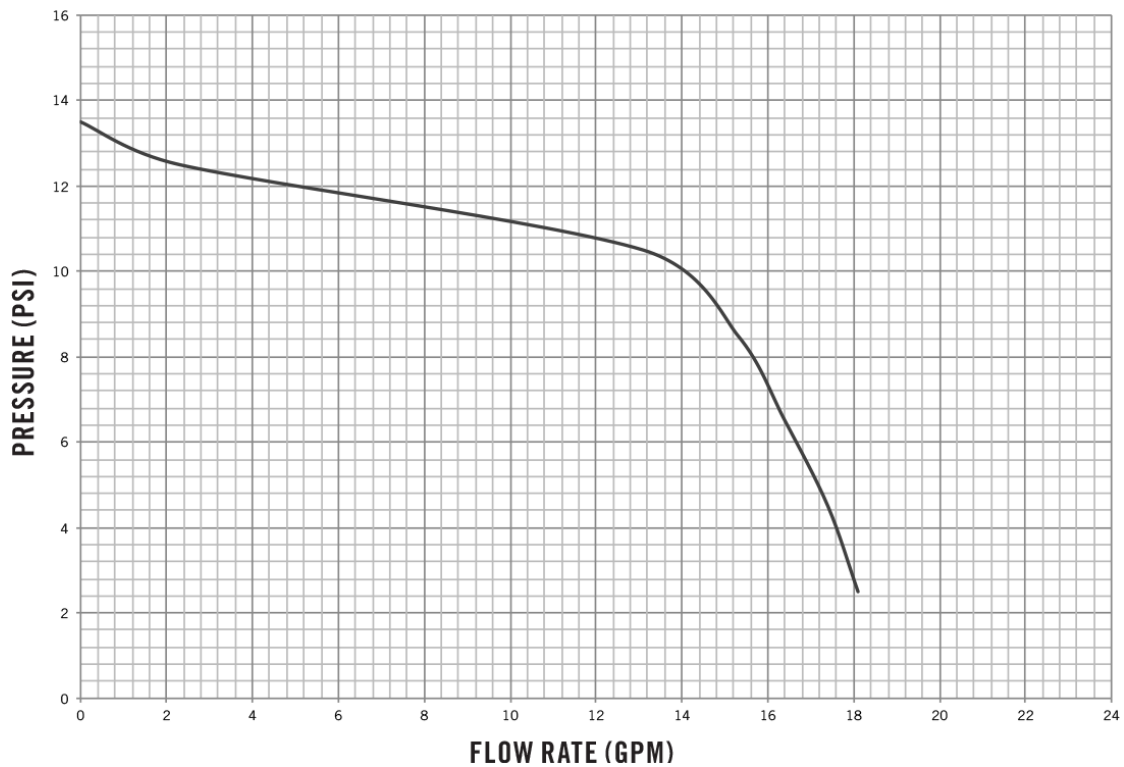

2400 Series Performance Curve

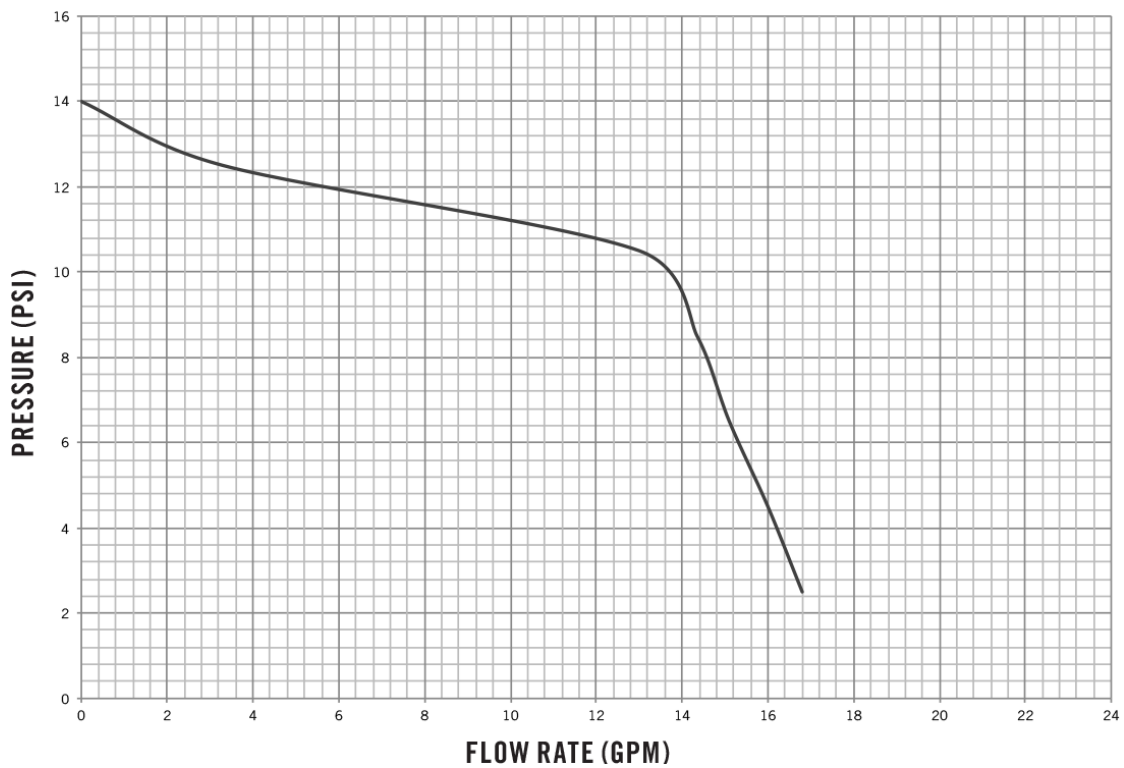

4200 Series Performance Curve

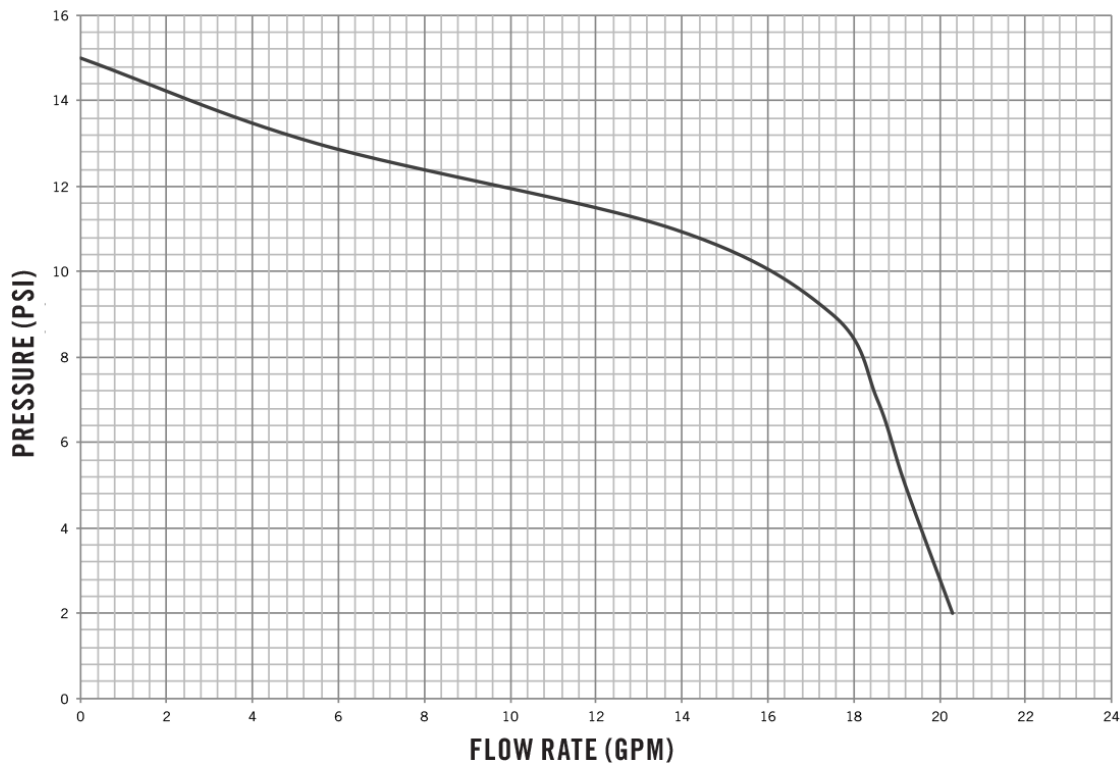

4400 Series Performance Curve

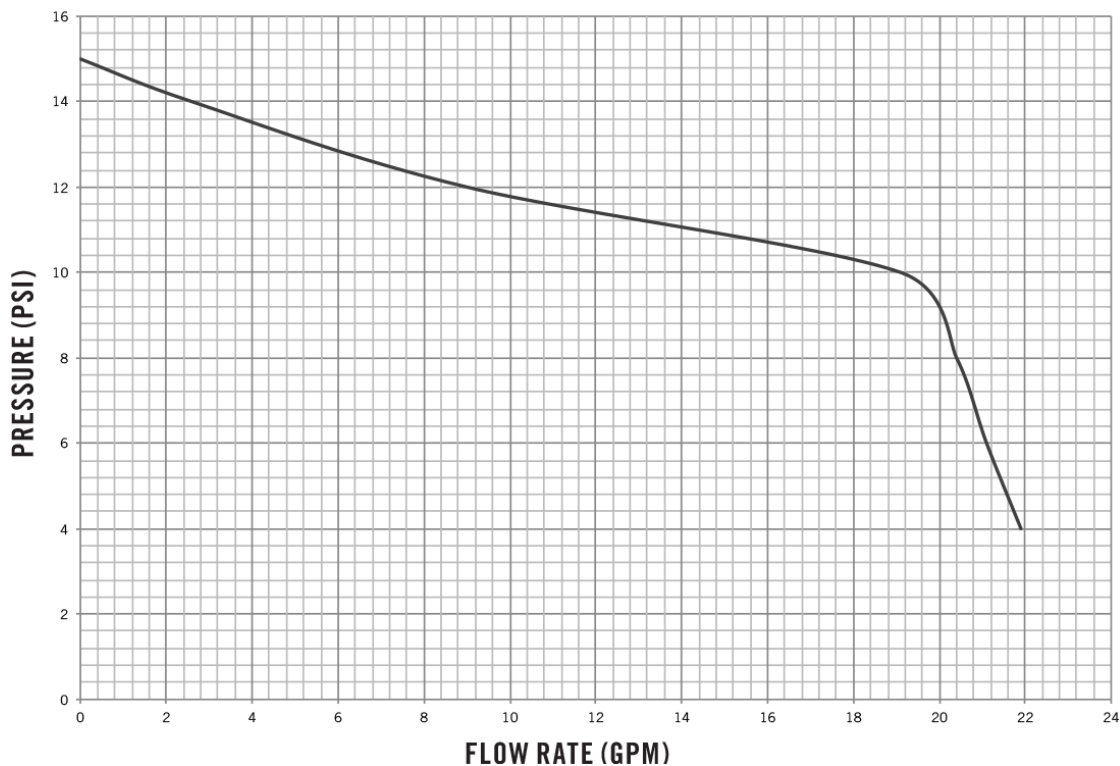

600 Series Performance Curve

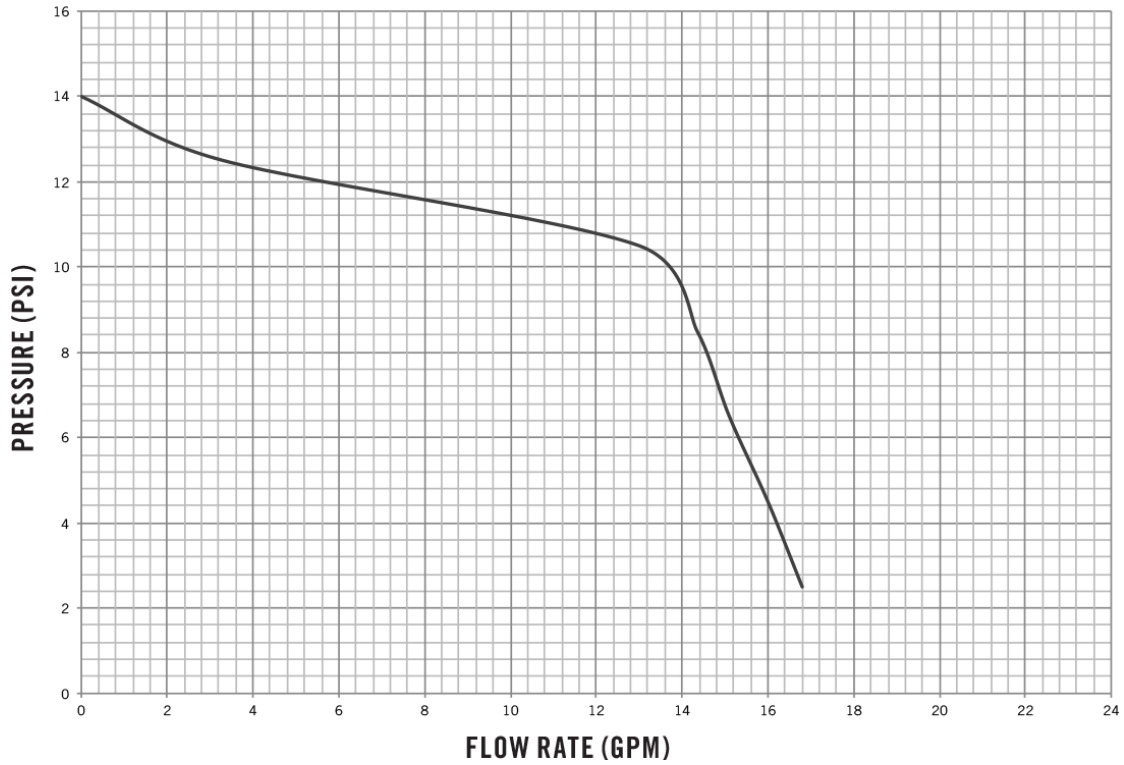

Accessories

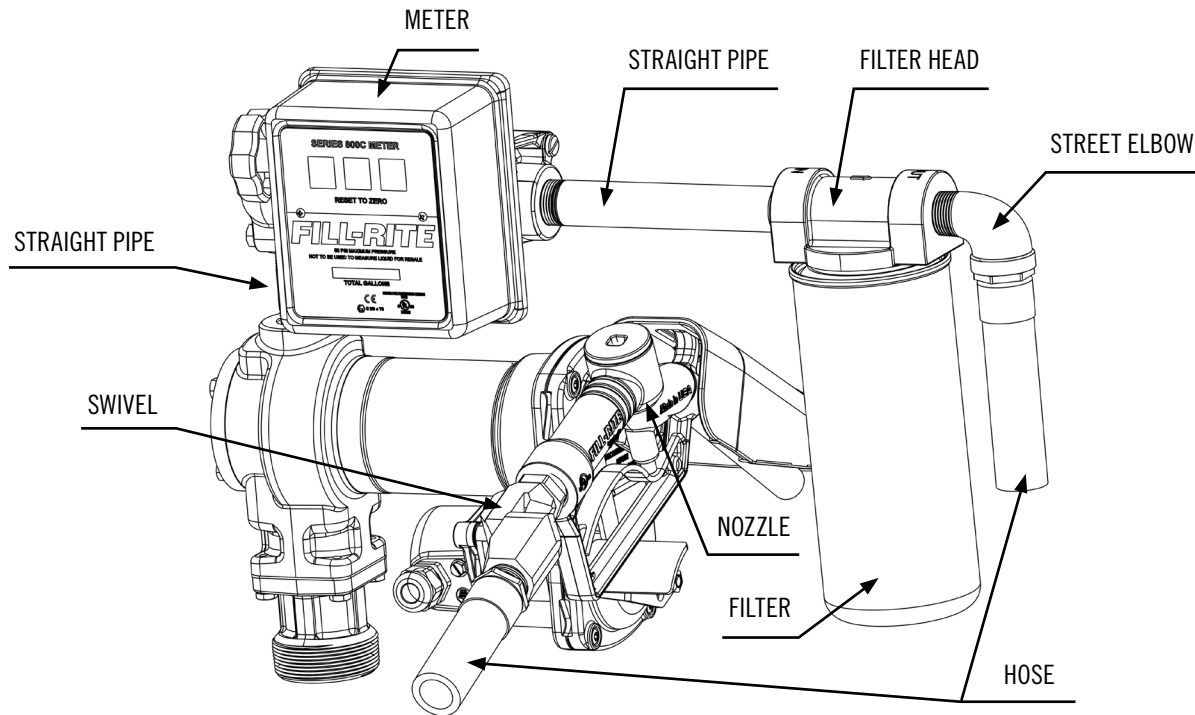

Proper Accessory Configuration

Accessories (continued)

Accessory	Series		Outlet Size		Notes
			3/4"	1"	
Nozzle	Manual		FRHMAN075S	FRHMN1005	Gasoline/Diesel
	Automatic	Hi-Flow	N075UUAU10	N100DAU12	Red Boot
			N075DAU10	N100DAU12G	Green Boot
		Arctic	FRNA075DAU10	FRNA100DAU00	Cold Weather (-40°F/°C)
		Ultra Hi-Flow			N100DAU13
				N100DAU13G	Green Boot
			N100DAU13Y	Yellow Boot	
Hose	12', UL Rated		700F3135	300F7773	Gasoline, Diesel, Kerosene, and Petroleum Oils compatible
	12'		FRH07512	FRH10012	
	14'		FRH07514	FRH10014	
	20'		FRH07520	FRH10020	
Meter	Mechanical	800	807CMK		Gallons
			807CLMK		Liters
		900		901CMK4200	Gallons
				901CLMK4200	Liters
	Digital	900		900CD	Programmable
				900CDP	Programmable with Integral Pulsar
		TT		TT10AB	BSPP, Aluminum
				TT10ABC	BSPP, Nickel-Plated
			TT10AN	NPT, Aluminum	
			TT10ANC	NPT, Nickel-Plated	
Swivel	Multi-Plane		S075H1314	S100H1315	360° Rotation
Filter	Heads		1200KTG9075 (F18 Filters)	700ACCF7017 (F40 Filters)	Gasoline/Diesel compatible
	Particulate		F1810PMO (10 Micron/18GPM)	F4010PMO (10 Micron/40GPM)	
				F4030PMO (30 Micron/40GPM)	
	Hydrosorb		F1810HMO (10 Micron/18GPM)		

Safety Testing Approvals

The Fill-Rite line of pumps have been safety tested for regulatory compliance. This product family is approved by UL/cUL. For the “E” series products they are approved to ATEX, IECEx, INMETRO, EAC, and CE.



The following standards were used to show compliance in the European Union:

EN IEC 60079-0:2018, Ed 7 “Explosive atmospheres – Part 0: Equipment – General requirements”

EN 60079-1:2014, Ed 7 “Explosive atmospheres – Part 1: Equipment protection by flameproof enclosures “d””

EN ISO 80079-36:2016, Ed 1 “Explosive atmospheres – Part 36: Non-electrical equipment for explosive atmospheres – Basic method and requirements”

EN ISO 80079-37:2016, Ed 1 “Explosive atmospheres – Part 37: Non-electrical equipment for explosive atmospheres – Non electrical type of protection constructional safety “c”, control of ignition source “b”, liquid immersion “k””

Directive 2014/34/EU – Equipment and protective systems intended for use in potentially explosive atmospheres.

Directive 2011/65/EU – Restrictions of the use of certain hazardous substances in electrical and electronic equipment.

The following standards were used to show compliance for IECEx certification:

IEC 60079-0:2017, Ed 7
IEC 60079-1:2014, Ed 7

Motor Tag Information

The Motor Tag on your Fill-Rite pump contains important technical and performance information. Be certain this label remains affixed to the pump at all times.



II 2 G
Ex db h IIA T5 or T6 Gb
FM19ATEX0019X
IECEX FMG19.0013X
Ex db IIA T5 or T6 Gb

Installation

Pump must be installed in compliance with EN 60079-14 or IEC 60079-14, as applicable.

Material of Construction

Materials of construction of the external surface of the unit: painted steel, painted cast iron, painted aluminum, zinc plated steel.

Materials of construction of the wetted parts: cast iron, zinc plated steel, 300 series stainless steel, bronze, carbon, ceramic, polyester, fiber, fluorocarbon, buna.

Repair and Maintenance

Contact the place of purchase for warranty repair and maintenance.

Specific Conditions of Use

1. Consult the manufacturer if dimensional information on the flameproof joints is necessary.
2. ISO Class 4.6, M5 hex-head screws (Yield Stress 240 MPa) shall be used to replace the DC Motor terminal cover fasteners.
3. ISO Class 8.8, M6 hex-head screws (Yield Stress 640 MPa) shall be used to replace the DC Motor motor tie-rod fasteners.
4. An electrically conductive hose and nozzle must be used with flammable liquids. To minimize static electricity buildup, always keep the nozzle in contact with the container being filled during the fueling process.

Motor Tag Information

The motor tag on your Fill-Rite pump contains important technical and performance information. Be certain this label remains affixed to the pump at all times.

FILL-RITE		MADE IN U.S.A. LB002540-009	
STYLE FM12001X	Segurança		
EXPLOSION PROOF MOTOR	IEx	INMETRO	IEEx10.0005X Ex db IIA T6 Gb
12 VOLTS DC	20 MIN. DUTY	IEEx	FM19.0013X
55°C RISE	30 MIN. DUTY	INMETRO	Ex db IIA T6 Gb
1/4 HP	2600 RPM	EAC	
ENTRY THREADS ARE M20X 1.5 6H		II 2 G Ex db h IIA T5 or T6 Gb FM19ATEX0019X	
CAUTION – MOTOR HAS AUTOMATIC RESET THERMAL PROTECTOR		2809	

FILL-RITE

A GORMAN-RUPP COMPANY

Fill-Rite Company
8825 Aviation Drive
Fort Wayne, Indiana 46809 USA

T 1 (800) 720-5192
1 (260) 747-7524
F 1 (800) 866-4681



fillrite.com | soter.com | gormanrupp.com